

High Productivity Cooking Smart Electric Boiling Pan 200lt, 600mm tilting height

ITEM # _____

MODEL # _____

NAME # _____

SIS # _____

AIA # _____

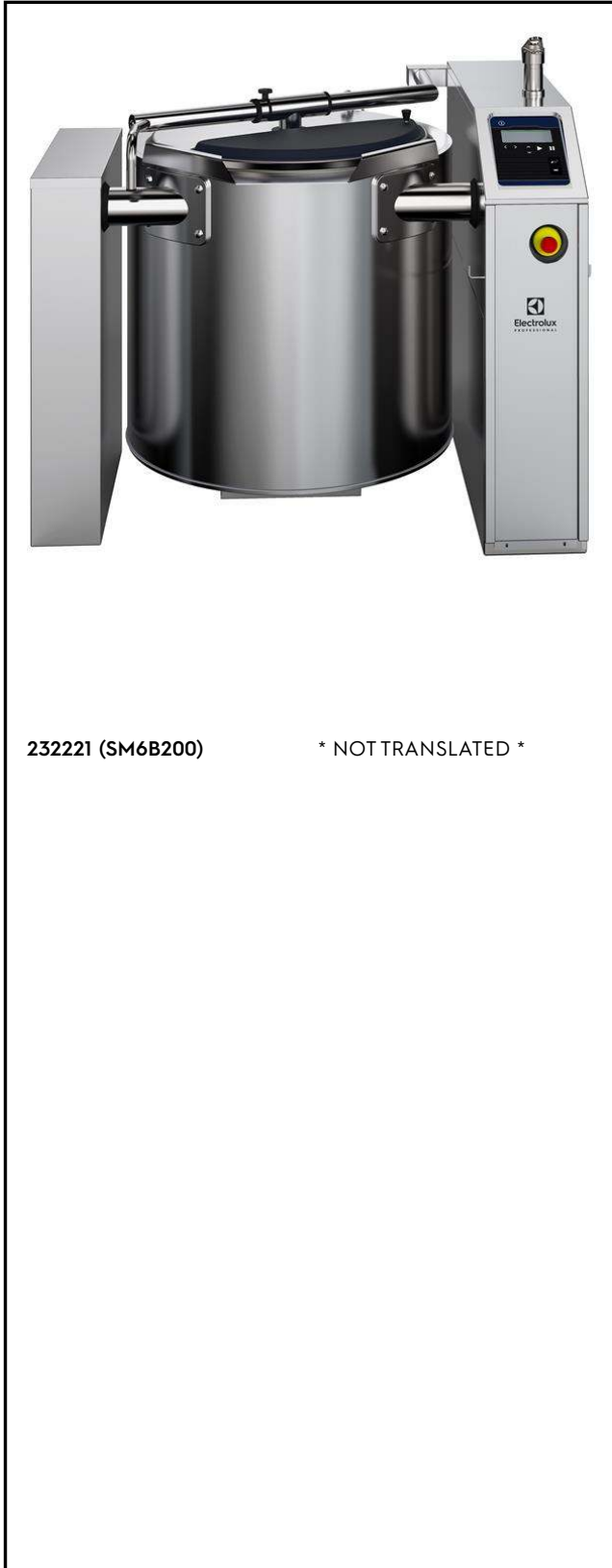

232221 (SM6B200)

* NOT TRANSLATED *

Main Features

- Curved pan base guarantees that the appliance is also suitable to prepare small quantities of food.
- Safety valve avoids overpressure of the steam in the jacket.
- Safety thermostat protects against low water level.
- Compliant to CE requirements for safety.
- Constructed to meet the highest hygiene standards.
- Safe thanks to the higher water protection IPX5 and the lower temperature outside the panels.
- Fast working thanks to the high efficient heating technology and well insulation that keeps the heat inside the well.
- High thermal input and fast heat up.
- Isolated upper well rim avoids risk of harm for the user.
- Food is uniformly heated through the base and side walls of the pan by an indirect heating system which uses integrally generated saturated steam at a temperature of 120°C in a jacket with an automatic deaeration system.
- 600 mm tilting height minimum.
- Electronic control with possibility to store up to 50 programs, large display for easy use and a complete control over the following functions: start, cooking time, temperature and water filling.
- OPTIONS (to be ordered with the machine and must be installed in the factory):
 - Spray gun - integrated spray unit

Construction

- Vessel can be tilted beyond 90° to completely empty the food.
- Motorised tilting.
- Ergonomic and user friendly thanks to the high tilting position and the pouring lip design which allow to easily fill containers.
- Max pressure 1,5 bar.
- Heavy duty, balanced stainless steel lid with sliding plastic cover to insert ingredients. Easy to remove and turn to facilitate cleaning.
- Tilting axis located at the front and upper position of the pan to keep the pouring path short when filling different types of vessels.
- AISI 304 stainless steel construction with AISI 316 stainless steel deep drawn pan with rounded edges.

Sustainability



- High-quality thermal insulation of the pan saves energy and keeps operating ambient temperature low.

Optional Accessories

- Strainer 200lt PNC 928027 □

APPROVAL: _____

Front

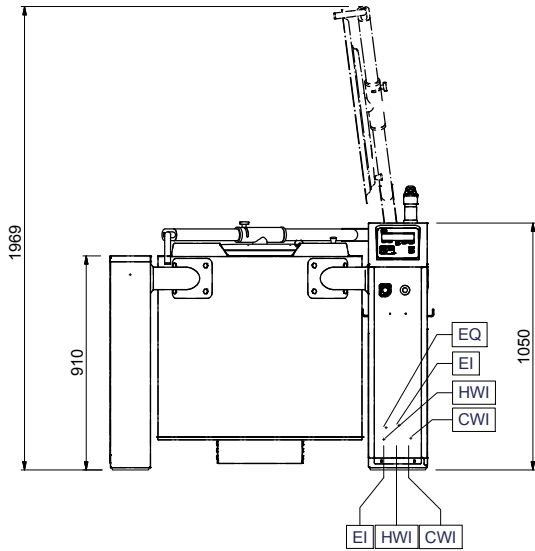

Side

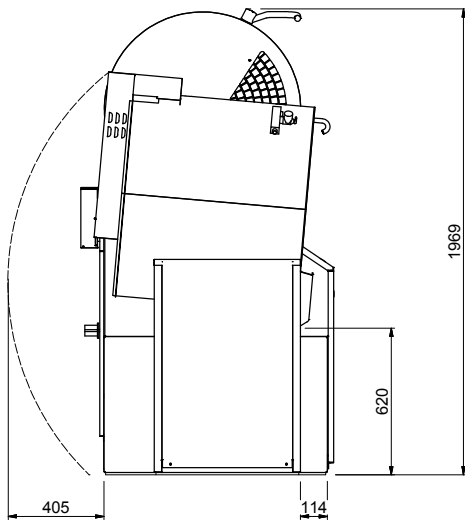

- CWI = Cold Water inlet 1
- EI = Electrical inlet (power)
- HWI = Hot water inlet

Top

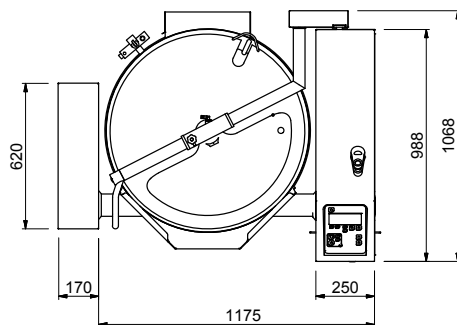

Electric

Supply voltage: 400 V/3N ph/50-60 Hz
Electrical power max.: 37.5 kW

Installation:

Distance back floor tilted: 620 mm

Key Information:

Working Temperature MIN: 30 °C
Working Temperature
MAX: 121 °C
Vessel (round) diameter: 742 mm
Vessel (round) depth: 555 mm
External dimensions,
Width: 1345 mm
External dimensions,
Depth: 1070 mm
External dimensions,
Height: 1050 mm
Net vessel useful capacity: 200 lt
Tilting mechanism: Automatic
Bearing: Front